

**Product Data – Positioners****Preston-Eastin Model PA-100 HD12****Capacity**

- Weight: 10000 pounds
- Offset of C.G. from table: 12 inches
- Eccentricity of C.G. from axis: 12 inches

**Rotation**

- Motor: Variable speed DC, 3 horsepower
- Speed range: 0.03 to 0.86 rpm
- Speed accuracy: 2% of set speed

**Tilt**

- Motor: AC brakemotor, 3 horsepower
- Range: 135 degrees forward tilt
- Inherent overhang: 9.00 inches

**Elevation:**

- Adjustment: Manual
- Range: 49 inches to 73 inches in 6 inch increments

**Table:**

- Diameter: 54 inch square with four radial T-slots
- Mounting bolt size: 3/4 inch
- Bearings: Timken tapered roller bearings
- Ground: 2 each 600 amp spring-loaded mechanical ground

**Controls**

- Pendant: Remote pendant, 115V, w 30 foot cable
- Rotation speed: One-turn potentiometer
- Rotation mode: Two-position selector switch, WELD/RAPID
- Rotation direction: Three-position selector switch, FWD/OFF/REV
- Rotation control: START and STOP pushbuttons
- Tilt directional control: Three-position momentary switch, UP/OFF/DOWN
- Power: 460/230V, 15/30A, three phase, 60 hertz.
- Overload protection: Circuit breaker
- Foot switch: Optional

**Weight**

- Shipping weight: 6250 pounds

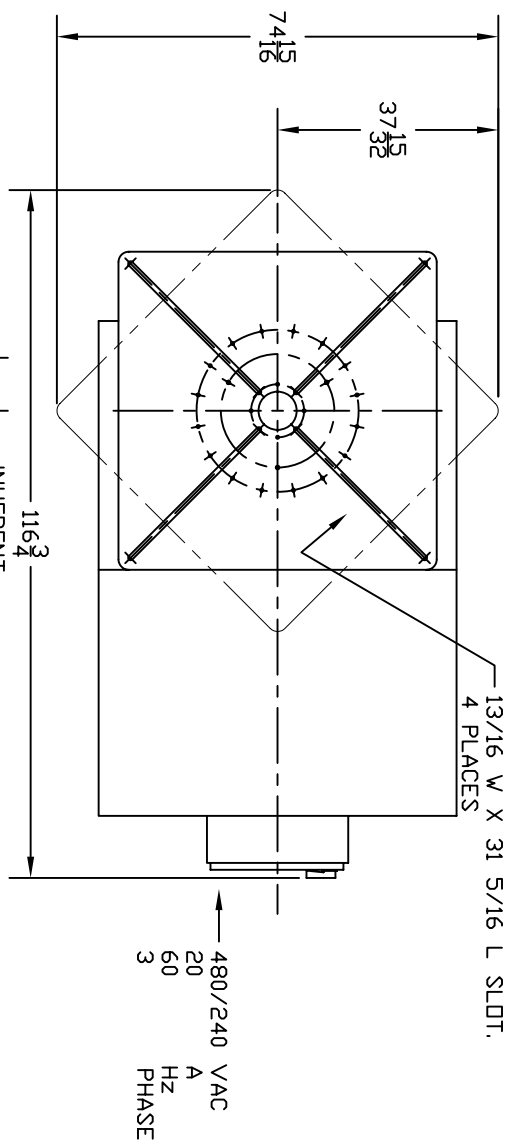
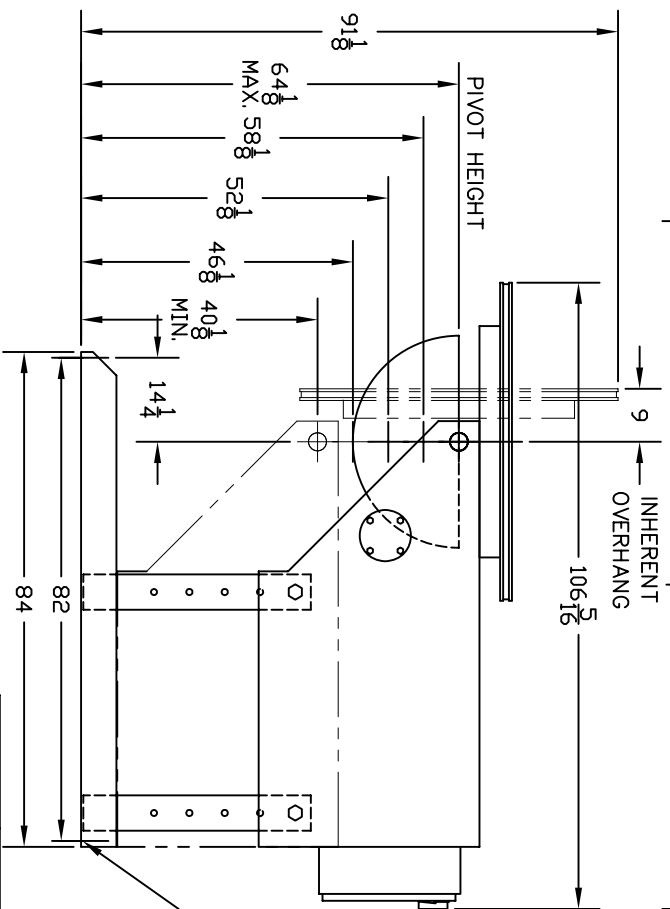
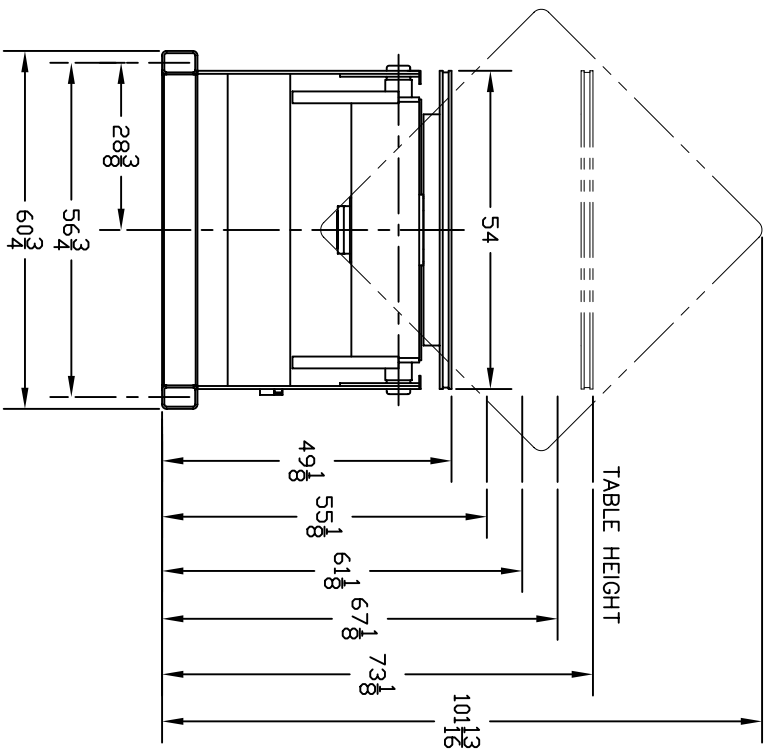

TULSA		OKLAHOMA	
PRESTON-EASTMAN INC.		20148	
PA-100 HD-12		DIMENSIONAL OUTLINE	
DATE	REV.	BY	CHK'D
4-25-79		B.A.K.	
5-25-88			
THIS DRAWING AND THE DESIGN HEREIN ARE THE PROPERTY OF PRESTON-EASTMAN INC. REPRODUCTION AND/OR USE WITHOUT WRITTEN PERMISSION IS PROHIBITED.			